

SECTION 00007 – ADDENDUM NUMBER 7

DATE: **January 20, 2015**

TO: **ALL BIDDERS**

FROM: **CLARK C. BURRITT, PRINCIPAL ARCHITECT
CITY OF WORCESTER
DEPARTMENT OF PUBLIC WORKS AND PARKS
50 SKYLINE DRIVE
WORCESTER, MA 01605**

RE: **REGIONAL EMERGENCY COMMUNICATIONS CENTER
2 COPPAGE DRIVE, WORCESTER, MA 01603**

THIS ADDENDUM FORMS A PART OF THE CONTRACT AND MODIFIES THE ORIGINAL DOCUMENTS DATED DECEMBER 11, 2014.

PART 1 - GENERAL

- 1.1** This addendum must be returned with plans and specifications (if not already returned) to have your deposit returned.
- 1.2** This addendum modifies, amends, and supplements the Contract Documents for the above referenced project. This addendum is hereby made a part of the Contract Documents by reference and shall be as binding as though inserted in locations designated hereunder.
- 1.3** Each general bidder shall be responsible for notifying all his non-filed sub-bidders and suppliers of the content of this addendum. No claim for additional compensation will be considered because of lack of knowledge of changes or modifications contained in this addenda.
- 1.4** Questions or requests for clarification shall be in writing, addressed to Jeremy C. Flansburg at **DEPARTMENT OF PUBLIC WORKS AND PARKS, ARCHITECTURAL DIVISION**, and may be sent to fax number: (508) 799-8188. Please include your name, phone number, and fax number with your fax.
- 1.5** Part 2 of this addendum indicates revisions to the Project Manual.
- 1.6** Part 3 of this addendum indicates revisions to the Drawings.
- 1.7** Part 4 of this addendum indicates clarification to Contractors Questions.

PART 2 - SPECIFICATIONS

- 2.1** **SPECIFICATION SECTION 001000 – INVITATION TO RE-BID/NOTICE TO CONTRACTORS, Insert Invitation to Re-Bid attached for ELECTRICAL re-bid.**
- 2.2** **SPECIFICATION SECTION 005000 FORM OF SUB RE-BID, Revised Forms attached for the Electrical Re-Bid.**
- 2.3** **1.1 SPECIFICATION 088000 GLAZING;** revise 1.3 SUMMARY paragraph A. as follows:
1. Glass for glazed curtain walls and curtain wall entrance.
 2. Mirrors as specified in Section 088300 (issued in Addendum 1).
 3. Interior Storefront: All glass interior partitions as specified in Section 084126 (issued in Addendum 2, section title revised in Addendum 3).
 4. Interior Counter Sliding Windows: Window type 1A (see sketch in this addendum).
- 2.4** **ELECTRICAL CONTRACTORS** shall include in BASE BID ALL site lighting.

PART 3 - DRAWINGS

- 3.1** **DRAWING – ALL SITE LIGHTING** on Drawing C 4.2 shall be included in ELECTRICAL Filed sub-Re-Bid Base Bid
- 3.2** **SKETCHES ADD the following sketch (attached) to revise currently issue drawings:**
1. **SKA-04 SLIDING WINDOW ‘1A’ DETAIL** Revise all drawings accordingly.
 2. **SKH-01 TELCO/ELEC RM A/C UNIT AND CONDENSER REVISIONS** Revise all drawings accordingly.

PART 4 - CONTRACTOR QUESTIONS

- 4.1** **QUESTION:** Regarding the Re-bid of the Glass & Glazing Section 0888000-Worcester RECC Project which bids 1-28-15, should we return the plans & specs that we have and pick up a new set of plans and specs or will the information to bid be the same?
ANSWER: Keep your drawings, the Re-bid is based on the same plans and specifications. Please note the Electrical portion of the work is also being Re-bid. Glazing and HVAC e-Bids are due 1-28-2015 @ 11:00 a.m. Electrical Re-Bids are due 2-4-2015 @ 11:00 a.m.

END OF ADDENDUM NUMBER 7



CITY OF WORCESTER
INVITATION TO RE-BID / NOTICE TO CONTRACTORS
REGIONAL EMERGENCY COMMUNICATIONS CENTER
2 COPPAGE DRIVE
Worcester, Massachusetts 01603

The City of Worcester, the Awarding Authority, invites sealed re-bids for: **REGIONAL EMERGENCY COMMUNICATIONS CENTER, 2 Coppage Drive, Worcester, Massachusetts 01603** in accordance with documents prepared by Clark C. Burritt, Principal Architect, Department of Public Works & Parks, Architectural Services Division, 50 Skyline Drive, Worcester, MA 01605.

The project scope generally includes construction of steel building and interior buildout consisting of plumbing, HVAC, fire protection and electrical and any other related work

SEALED FILED SUB-RE-BIDS for **REGIONAL EMERGENCY COMMUNICATIONS CENTER** will be received at the Department of Public Works and Parks, Architectural Services Division, 50 Skyline Drive, Worcester, MA 01605 no later than 11:00 a.m., Wednesday, February 4, 2015 and will be publicly opened thereafter and read aloud.

Filed Sub-Bids required are as follows:

(1) Section 260000 ELECTRICAL
SUB-RE-BIDS must be accompanied by:

- (1) A fully executed FORM FOR SUB-BID;
Specification Section 00500.
- (2) Certification of Payment of Massachusetts State Taxes Form;
Specification Section 00850.
- (3) **Affidavit of Acknowledgment and Certificate of Compliance** for the City of Worcester Minority/Women Business Enterprise & Worker Utilization. **M/WBEP-Form EOO-101;**
Specification Section 00900.
- (4) **Initial Statement and Certification of Compliance** with the Responsible Employer Ordinance, **Form REO-101 page 2, Specification Section 00950.**
- (5) **Provide Evidence** of Compliance with the Responsible Employer Ordinance (**REO**). **As per Specification Section 00950.**
- (6) **A Certificate of Eligibility** certifying the bidders qualification, in the respective filed sub trade category being bid, issued by the Division of Capital Asset Management, DCAM (formerly the Division of Capital Planning and Operations, DCPO), showing that the Bidder has been approved to bid on projects the size and nature of this project. In order to be eligible to be awarded this contract, a bidder must be certified in the appropriate category and for the total Cost of the respective work including all alternates elected (if applicable) to be taken by the Owner.
- (7) **A Contractor Update Statement**, DCPO FORM CQ3. It is the Bidder's responsibility to obtain the necessary forms and make application to DCAM (DCPO) in sufficient time for DCAM

(DCPO) to evaluate the application and issue a Certificate of Eligibility. A sample of the **Contractor Update Statement**, DCAM FORM CQ3 (revised December, 1999) is located at the end of Section 00150.

- (8) Bid deposit for the sub-bid in the amount of **five (5) percent** of the value of the bid, or a bid bond.
- (9) **Foreign Corporation Certificate of Registration** from the Commonwealth of Massachusetts State Secretary (if applicable).

Plans and Specifications will be available Wednesday, January 21, 2015 at the Department of Public Works and Parks, Architectural Services, 50 Skyline Drive, Worcester, MA 01605, Phone: (508) 799-8588, Fax: (508) 799-8188. Plans and specifications are also available at <http://bids.worcesterma.gov/>.

- (1) A **refundable plan deposit** in the form of a company check (cash not accepted), without date restrictions, payable to "City of Worcester" in the amount of \$50.00 per set for up to three (3) sets is required. If additional sets are required, a separate non-refundable check in the amount of \$50.00 per set is required. Deposits for up to three (3) sets shall be returned to the bidders who return the complete sets, including any addenda issued, in good condition to the Department of Public Works and Parks, Architectural Services, 50 Skyline Drive, Worcester, MA 01605 within thirty (30) days after the bid opening.
- (2) If **plans** and **specifications** are requested to be mailed, a separate non-refundable shipping and handling/ mailing fee in the form of a company check payable to "City of Worcester" in the amount of \$50.00 is required per set.
- (3) A "Contractor's Plans and Specifications Request Form" is required to be filled out to obtain **plans** and **specifications** via the Architectural Services Division. Forms are available at the Department of Public Works and Parks, Architectural Services, 50 Skyline Drive, Worcester, MA 01605, Phone: (508) 799-8588, Fax: (508) 799-8188.
 - (a) After receipt of Contractor's Plans and Specifications Request Form, deposit and mailing fee, plans and specifications will be shipped via UPS.
- (4) **PARTIAL SETS WILL NOT BE ISSUED OR MAILED.**

Contract Documents may be viewed, but not removed, at the following locations:

Architectural Services
Department of Public Works and Parks
50 Skyline Drive
Worcester, MA 01605

WAGE RATES - Bids are subject to the provisions of M.G.L., Chapter 149, Section 44A to J inclusive, as amended to date, and such other Federal, State and Municipal laws or regulations.

Attention of bidders is particularly called to the requirements as to conditions of employment to be observed and to the fact that not less than the minimum wage rates set forth in the Contract Documents shall be paid on this project. Minimum wage rates are per M.G.L., Chapter 149, Sections 26 & 27 inclusive.

MINORITY/WOMEN BUSINESS ENTERPRISE PROGRAM - The City of Worcester has established goals for the participation of minorities and women workers, contractors, subcontractors, and suppliers on all City projects. Bids must demonstrate the contractor's ability to utilize minorities and women in all phases of this project. The City of Worcester has established a program to enhance contract opportunities to minority and women-owned businesses through its Minority/Women Business Enterprise Program. This program contains minimum participation goals of ten (10) percent by MBE's and five (5) percent by WBE's calculated as a percentage of the total bid price. Accordingly, all general bidders and filed sub-bidders must execute and submit with their respective bids M/WBEP Form EOO-101, Contractor's and Filed Subcontractor's Certification.

RESPONSIBLE EMPLOYER ORDINANCE - The performance of the work derived from this bid is subject to the City's Responsible Employer Ordinance, Chapter 2, Section 35 of WRO (2008). Accordingly, all general bidders and filed sub-bidders must execute and submit with their respective bids Form REO-101 page 2, Contractor's and Filed Subcontractor's Initial Certification.

NOISE ORDINANCE – **All Contractors must adhere to the provision of § 1A(e)(9) of chapter nine of the Revised Ordinances of the city by limiting their on-site, noise producing construction and related work to the hours specified by said ordinance.**

PRE-BID CONFERENCE - The pre-bid conference will be held on Friday, January 23, 2015 at the project site, 2 Coppage Drive, Worcester, 01603 beginning at 10:00 a.m. with a brief overview and tour of the construction areas. It is recommended that all Bidders attend this meeting.

WORK UNDER SEPARATE CONTRACTS AND BY OWNER – The Owner may do other work during construction with its own forces or by separate contract.

COMMENCEMENT OF WORK AND TIME OF COMPLETION – The selected General Bidder must agree to commence work within five (5) days of the execution of a General Contract and to substantially complete on October 13, 2015 in accordance with the project schedule set forth in the contract documents.

The Awarding Authority reserves the right to waive any informality in, or to reject any or all general bids, if it were in the public interest to do so. In inviting sub-bids in connection with such a contract, the Awarding Authority shall reserve the right to reject any sub-bid on any sub-trade, if it determines that such sub-bid does not represent the sub-bid of a person competent to perform the work as specified, or that less than three (3) such sub-bids were received and that the prices are not reasonable for acceptance without further competition.

The City of Worcester is an equal opportunity/affirmative action employer.

City of Worcester, Massachusetts
Executive Office of the City Manager

END OF DOCUMENT



**CITY OF WORCESTER
FORM FOR SUB—RE-BID**

SUB-TRADE: _____

NAME OF SUB-BIDDER: _____

This bid must be accompanied by a bid deposit in the form of cash, or a bid bond, or a certified check, treasurer's check, or cashier's check, payable to the City of Worcester (hereinafter referred to as the "Owner" or the "Awarding Authority") in the amount of five (5) percent of the value of the bid. No other form of bid security will be accepted.

By submitting this bid the undersigned represents to the Owner that it has examined and understands the Advertisement for Bids, Instructions to Bidders, Contract Forms, Conditions of the Contract (General and Supplementary), Drawings, Specifications and all other Contract Documents and has examined the site, as defined therein, and that this bid is made with distinct reference and relation to all said Contract Documents, but the undersigned declares that in regard to the conditions affecting the work to be done and the labor and materials needed, this bid is based solely on its own investigation and research and not in reliance upon any drawings, surveys, measurements, dimensions, calculations, estimates, or other tests or representations of any employee, officer, agent or consultant of the Owner. By submitting this bid, the undersigned agrees that it shall be subject to the jurisdiction of the courts of the Commonwealth of Massachusetts with respect to any actions arising out of or relating to this bid or any contract that may be entered into based upon this bid, and that any such actions commenced by the undersigned shall be commenced in the courts of the Commonwealth of Massachusetts.

A bidder wishing to amend this bid after transmittal to the Owner may do so only by withdrawing this bid and resubmitting another bid prior to the time for opening bids. See: General Bid Form

To all General Bidders except those excluded:

- A. The undersigned proposes to furnish all labor and materials required for completing the Work specified in Section(s) _____ of the Specifications for the Regional Emergency Communications Center, 2 Coppage Drive, Worcester, Massachusetts 01603, in accordance with the accompanying Drawings, Specifications and Addenda, prepared by Clark C. Burritt, Principal Architect, Department of Public Works & Parks, Architectural Services Division, 50 Skyline Drive, Worcester, MA 01605, for the contract price specified below, subject to additions or deductions according to the terms of the Plans and Specifications.

B. This Bid includes Addenda numbered _____.

C. The Proposed Contract Price is:
_____ Dollars (\$_____)

Alternates (refer to Section 012300, Alternates for a complete description of alternates):

Alternate Number 1: State the amount to be ADDED for All Site Work as currently planned.

\$_____

Alternate Number 2: State the amount to be ADDED for the Covered Trailer Storage Building.

\$_____

Unit Prices

C. Unit Prices (refer to Section 012200, Unit Prices for a complete description of Unit Prices):

1. Carry in the Base Bid a quantity of (31) 50 KIP piles/pile caps plates and extensions (Pile at exterior wall).

\$_____ per pile/pile cap plate and extensions (add or deduct).

2. Carry in the Base Bid a quantity of (21) 50 KIP piles/pile caps plates and extensions (Pile at interior column).

\$_____ per pile/pile cap plate and extensions (add or deduct)

D. To restrict General Bidders, insert "X" on one option only and fill in blanks following that selection. If no General Bidders are excluded disregard this item.

_____ **“RESTRICTED FROM”** – This Sub-bid may be used by any General Bidder except:

_____ **“RESTRICTED TO”** – This Sub-bid may be used only by the following General Bidders:

E. The names of all persons, firms and corporations furnishing to the undersigned labor or labor and materials for the class or classes or part thereof of work for which the provisions of the section of the specifications for this sub-trade require a listing in this

paragraph, including the undersigned, if customarily furnished by persons on his own payroll and in the absence of a contrary provisions in the specifications, the name of each such class of work or part thereto and the bid price for such class of work or part thereof are:

NAME	CLASS OF WORK	BID PRICE

(Do not give bid price for any class or part thereof furnished by undersigned.)

- F. The undersigned agrees that, if he is selected as a sub-bidder, he will, within five (5) days, Saturdays, Sundays and legal holidays excluded, after presentation of a subcontract by the general bidder selected as the general contractor, execute with such General Bidder a subcontract in accordance with the terms of this sub-bid, and contingent upon the execution of the general contract, and, if requested so to do in the general bid by such general bidder, who shall pay the premiums therefore, furnish a performance and payment bond of a surety company qualified to do business under the laws of the Commonwealth of Massachusetts and satisfactory to the awarding authority, in the full sum of the subcontract price.

- G. The undersigned agrees that the above list of bids to the undersigned represents bona-fide bids based on the hereinbefore described drawings, specifications and addenda and that, if the undersigned is awarded the contract, they will be used for the work indicated at the amounts stated, if satisfactory to the Awarding Authority.

- H. The undersigned further agrees to be bound to the General Contractor by the terms of the hereinbefore-described drawings, specifications, including all general conditions stated therein, and addenda, and to assume toward him all the obligations and responsibilities that he, by those documents, assumes toward the Owner.

- I. The undersigned offers the following information as evidence of his qualifications to perform the work as bid upon according to all requirements of the drawings and specifications:
 - 1. The undersigned has been in the present business name _____ years.
 - 2. Has the undersigned ever failed to complete any work awarded? _____
 - 3. Provide a Bank Reference: _____
 - 4. List one or more recent project with names of the General Contractor and Architect on which you served as a Subcontractor for work of similar character as required for the above-named project.

PROJECT NAME	GENERAL	ARCHITECT	AMOUNT OF

	CONTRACTOR		CONTRACT

- J. The undersigned hereby certifies that he is able to furnish labor that can work in harmony with all other elements of labor employed or to be employed on the work and that he will comply fully with all laws and regulations applicable to awards made subject to Section 44A of Chapter 149 of the Massachusetts General Laws.

- K. The undersigned further certifies under penalties of perjury that this bid is in all respects bona-fide, fair and made without collusion or fraud with any other person. As used herein the word "person" shall mean any natural person, joint venture, partnership, corporation or other business or legal entity. The undersigned further certifies under penalties of perjury that the said undersigned is not presently debarred from doing public construction work in the Commonwealth under the provisions of Section Twenty-nine F of Chapter Twenty-nine, or any other applicable debarment provisions of any other Chapter of the Massachusetts General Laws or any rule or regulation promulgated there under.

- L. The undersigned hereby certifies that all employees to be employed at the worksite will have successfully completed a course in construction safety and health approved by the United States Occupational Safety and Health Administration that is at least 10 hours in duration at the time the employee begins work and who shall furnish documentation of successful completion of said course with the first certified payroll report for each employee; and that they will comply fully with all laws and regulations applicable to awards made subject to M.G.L. c.149 sec.44A-J.

Date	Print Name of Bidder
Social Security Number or Federal Identification Number	By _____ Name of Person Signing Bid and Title
Telephone Number	Business Street Address
Fax Number	City, State and ZIP Code

- M. The Bidder shall fill in the following information about its business organization.
 - 3. If the Bidder is a Corporation, indicate the state of incorporation.

President:	State of Incorporation:
Treasurer:	Secretary:
If a Foreign Corporation: (incorporated or organized under laws other than laws of the Commonwealth of Massachusetts)	Is the Corporation registered with the Secretary of State of Massachusetts? Yes _____ No _____
If the Bidder is selected for the work referred to above, it is required under Massachusetts General Laws, Chapter 30, Section 39L to furnish to the Awarding Authority a certificate of the Secretary of State stating that the Corporation has complied with Massachusetts General Laws, Chapter 181, Sections 3 and 5 and the date of such compliance.	

4. If the Bidder is a Partnership, give full names and addresses of all partners:

Name of Partner:	Residence Address:
Name of Partner:	Residence Address:
Name of Partner:	Residence Address:
Name of Partner:	Residence Address:

5. If the Bidder is an Individual, give residential address if different from business address:

Name:	Residence Address:
-------	--------------------

6. If the Bidder is an Individual doing business under a Firm name:

Name of Firm:	Business Address:
Name of Individual:	Residence Address:

7. Other form of business organization:

--

N. The Bidder will give below the name and address of the Surety Company who will sign the bonds.

Name:	Address:
-------	----------

END OF SECTION 005000

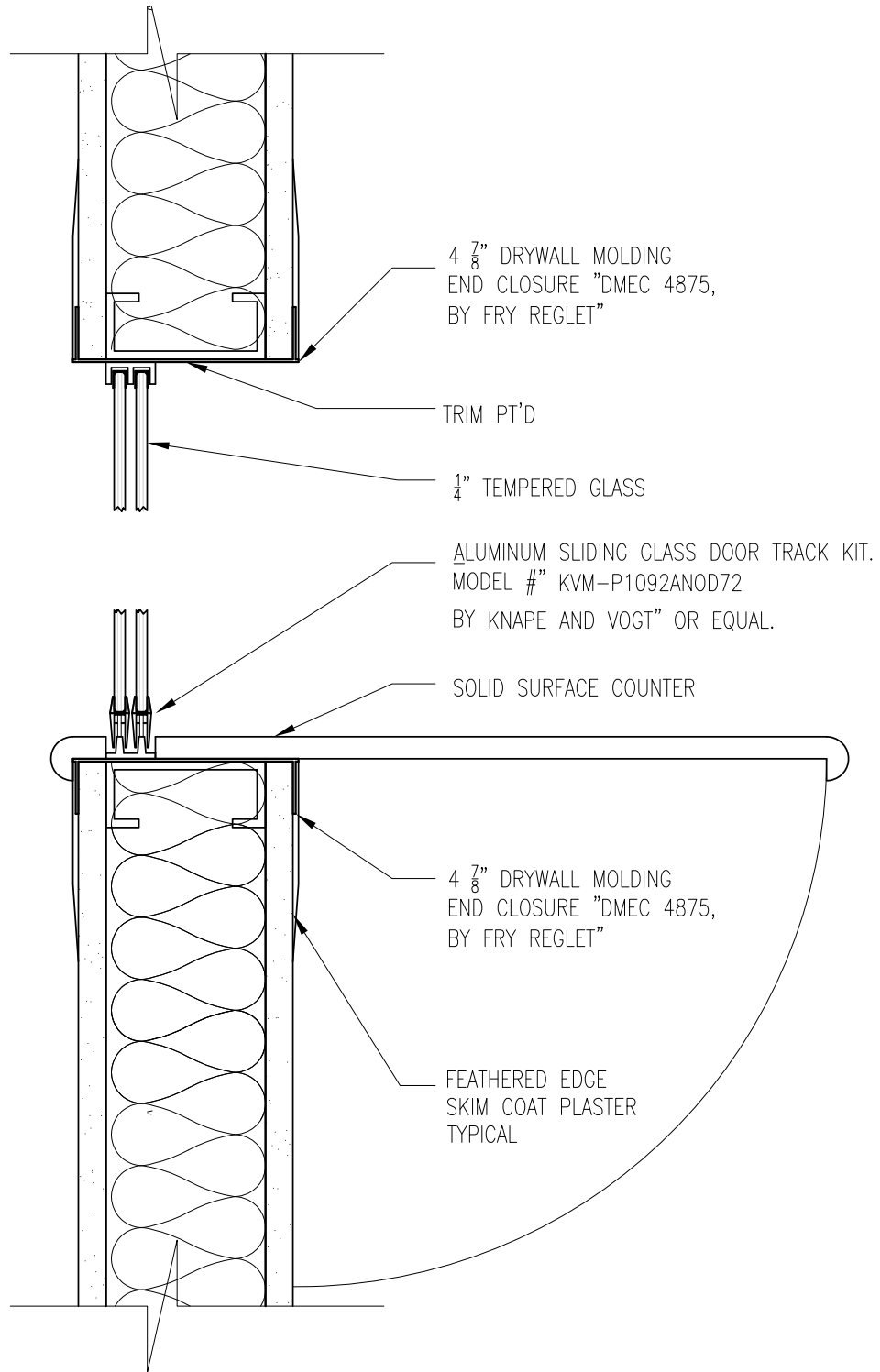

1 SILL & HEAD DETAIL @ WINDOW TYPE '1A'
3" = 1'-0"



CITY OF
DEPARTMENT OF
PUBLIC WORKS
AND PARKS
ARCHITECTURAL SERVICES DIVISION
50 SKYLINE DRIVE, WORCESTER, MA 01603

SCALE: 3" = 1'-0"
DATE: 01/20/15
REMARKS:
ISSUED VIA
ADDENDUM #7
REPLACES GLASS
DOOR TRACK REF.
ON SKA-01 DWG 1

PROJECT TITLE:
**REGIONAL EMERGENCY
COMMUNICATIONS CENTER**
2 Coppage Drive, Worcester, MA 01603
DRAWING TITLE:
SLIDING WINDOW '1A' DETAIL

SHEET NUMBER:
SKA-04

AIR-CONDITIONING UNIT

UNIT NUMBER	LOCATION	FAN(S)							DX EVAPORATOR COIL						ELECTRIC DATA				MANUFACTURER MODEL NUMBER (BASIS OF DESIGN)	REMARKS
		CFM	STATIC PRESS.(IN.WG)		QTY	HP EA	RPM	MBH		SST (°F)	EAT (°F)		FACE VELOCITY (FPM) (MAX)	MCA	V	Ø	HZ			
			TOTAL W/ DIRTY FILTERS	EXTERNAL				TOTAL	SEN-SIBLE		DB	WB								
AC-1 & 2	TELCO/ELEC	670	--	-	1	95 W	-	24	17.5	-	80	67	-	1.0	208	1	60	MITSUBISHI PCA-A24KA4	(1) (2) (3)	

- ① UNIT SHALL BE SERVED BY DEDICATED AIR-COOLED CONDENSING UNIT, SEE SPECIFICATIONS FOR ACCESSORIES.
- ② PROVIDE LITTLE GIANT CONDENSATE PUMP MODEL NUMBER VCMA-15ULS
- ③ INTERLOCK WITH CLEAN AGENT SYSTEM WHERE INDICATED ON PLANS. UPON ACTIVATION OF CLEAN AGENT SYSTEM, HVAC EQUIPMENT SHALL BE DE-ENERGIZED AND CONTROL DAMPERS SHALL BE CLOSED. COORDINATE WITH ELECTRICAL CONTRACTOR TO INSTALL A 2 POLE RELAY (LINE VOLTAGE) BETWEEN THE INDOOR AND OUTDOOR UNIT

AIR-COOLED CONDENSER

UNIT NO.	SERVICE	LOCATION	D.B. TEMP. (°F)	CONDENSER FAN(S)			ELECT. SERVICE				MANUFACTURER MODEL NUMBER (BASIS OF DESIGN)	REMARKS
				NO.	HP EA	CFM	MCA/MOCP	VOLTS	PHASE	HZ		
CU-1 & 2	AC-1	ROOF	95	1	75 W	1940	18/30	208	1	60	MITSUBISHI PUZ-A24NH44	(1) (2) (3)

- ① PROVIDE O'F CONTROLS, SEE SPECIFICATIONS FOR ACCESSORIES.
- ② PROVIDED FUSED DISCONNECT SWITCH.
- ③ INTERLOCK WITH CLEAN AGENT SYSTEM WHERE INDICATED ON PLANS. UPON ACTIVATION OF CLEAN AGENT SYSTEM, HVAC EQUIPMENT SHALL BE DE-ENERGIZED AND CONTROL DAMPERS SHALL BE CLOSED. COORDINATE WITH ELECTRICAL CONTRACTOR TO INSTALL A 2 POLE RELAY (LINE VOLTAGE) BETWEEN THE INDOOR AND OUTDOOR UNIT



BLW Engineers, Inc.
 311 Great Road, Post Office Box 1551
 Littleton, Massachusetts 01460
 T: 978.486.4301 F: 978.428.0067
 www.blwengineers.com
*HVAC * ELECTRICAL * PLUMBING * FIRE PROTECTION*

Project: RECC - WORCESTER, MA

Title: TELCO/ELEC RM A/C UNIT AND CONDENSER REVISIONS

Date: 12/30/14 Scale: NO SCALE Project No.: 12136.15

Drawn By: VS Rev. No.: 001 Dwg. Ref.: H0.3

Sketch No.:

SKH-01